



### Description & Features:

- A general-purpose gauge that is serviceable and pulsation resistant
- 1.5" (40mm) to 3.5" (90mm) dial sizes
- Dampened movement combined with a flutterless pointer
- Removable lens
- Zero-adjustment
- ASME B40.100 compliant
- CRN registered
- ±2-1-2% accuracy
- 5 year warranty

### Applications:

- Compressors, filters, regulators, water pumps, paint sprayers and a variety of other rapid pressure fluctuation applications
- Suitable for non-clogging and non-corroding media

### Specifications

<b>Dial</b>	1.5" (40mm), 2" (50mm), 2.5" (63mm), 3.5" (90mm) white aluminum with black and red markings
<b>Case</b>	Steel, painted black
<b>Lens</b>	Acrylic, threaded
<b>Socket</b>	Brass
<b>Connection</b>	1/8" NPT or 1/4" NPT standard
<b>Bourdon Tube</b>	Phosphor bronze
<b>Movement</b>	Brass (flutterless) with zero adjustment
<b>Pointer</b>	Aluminum, black
<b>Welding</b>	<1,000 psi: 60% tin 40% lead, ≥1,000 psi: silver alloy
<b>Over-pressure Limit</b>	25% of full scale value
<b>Working Pressure</b>	Maximum 75% of full scale value
<b>Ambient/Process Temperature</b>	-40°F to 150°F (-40°C to 65°C)
<b>Accuracy</b>	±2-1-2% ANSI/ASME Grade A
<b>Enclosure Rating</b>	IP52
<b>Warning</b>	<b>⚠ WARNING:</b> This product can expose you to chemicals including lead, which is known to the State of California to cause cancer and birth defects or other reproductive harm. For more information go to <a href="http://www.P65Warnings.ca.gov">www.P65Warnings.ca.gov</a> .

### 1.5" Bottom Connection

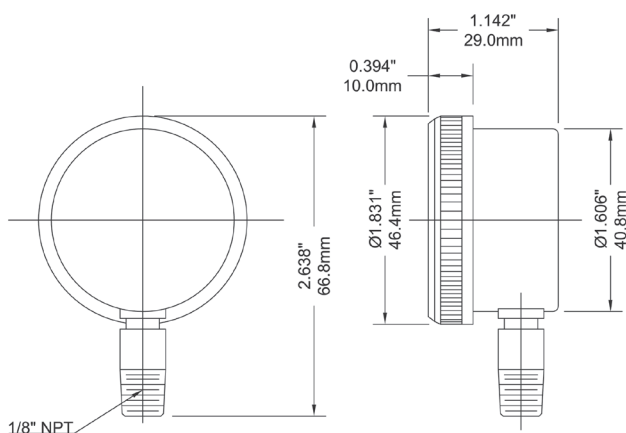

### 1.5" Back Connection

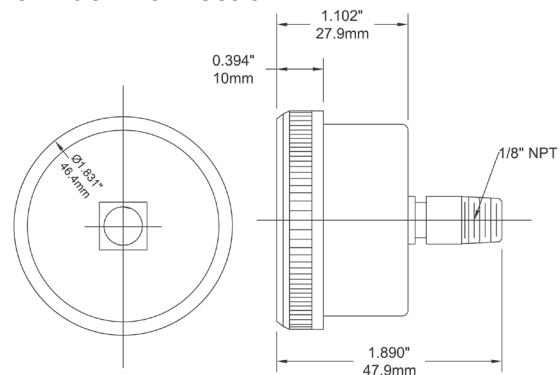

### Order Codes (products in bold are normally stock in North America)

Dial Size	1.5" (40mm)		2" (50mm)				2.5" (63mm)		3.5" (90mm)	
	1/8" Bottom	1/8" Back (CB)	1/8" Bottom	1/8" Back (CB)	1/4" Bottom	1/4" Back (CB)	1/4" Bottom	1/4" Back (CB)	1/4" Bottom	1/4" Back (CB)
30" Hg Vac/kPa	P9S901297	P9S901397	P9S90195	P9S901424	P9S90135	P9S901428	P9S90210	P9S901431	P9S90220	P9S901455
30"/0/15 psi/kPa	-	-	-	-	-	-	P9S90152	-	-	-
30"/0/30 psi/kPa	-	-	-	-	-	-	<b>P9S90153</b>	-	-	-
30"/0/60 psi/kPa	-	-	-	-	-	-	P9S90154	-	-	-
30"/0/100 psi/kPa	-	-	-	-	-	-	P9S90155	-	-	-
0/15 psi/kPa	P9S901299	<b>P9S901399</b>	P9S90196	P9S901425	<b>P9S90136</b>	<b>P9S901429</b>	<b>P9S90211</b>	P9S901436	P9S90229	P9S901464
0/30 psi/kPa	P9S901300	<b>P9S901400</b>	P9S90206	P9S901402	P9S90199	<b>P9S901403</b>	<b>P9S90212</b>	P9S901437	<b>P9S90221</b>	P9S901456
0/60 psi/kPa	<b>P9S901301</b>	P9S901401	P9S90207	P9S901404	P9S90201	<b>P9S901405</b>	<b>P9S90213</b>	P9S901438	P9S90222	P9S901457
0/100 psi/kPa	P9S901320	P9S901420	P9S90208	P9S901406	<b>P9S90202</b>	<b>P9S901407</b>	<b>P9S90214</b>	P9S901439	<b>P9S90223</b>	P9S901458
0/160 psi/kPa	P9S901321	<b>P9S901421</b>	P9S90197	P9S901408	P9S90203	<b>P9S901409</b>	<b>P9S90215</b>	P9S901440	P9S90224	P9S901459
0/200 psi/kPa	P9S901322	P9S901422	P9S90209	P9S901426	P9S90204	P9S901410	<b>P9S90216</b>	P9S901441	<b>P9S90225</b>	P9S901460
0/300 psi/kPa	P9S901323	P9S901423	P9S90198	P9S901427	P9S90205	P9S901411	P9S90217	P9S901442	P9S90226	P9S901461
0/400 psi/kPa	P9S901324	P9S901443	P9S901449	P9S901445	P9S901451	P9S901447	P9S90219	P9S901453	P9S90227	P9S901462
0/600 psi/kPa	P9S901325	<b>P9S901444</b>	P9S901450	P9S901446	P9S901452	P9S901448	P9S90218	P9S901454	P9S90228	P9S901463

Other ranges and connection sizes available upon request. For scale change, refer to How to Order Guide for scale codes.

### 2" Bottom Connection

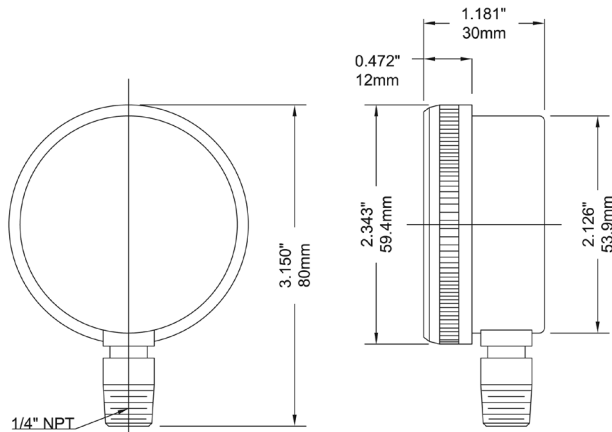

### 2" Back Connection

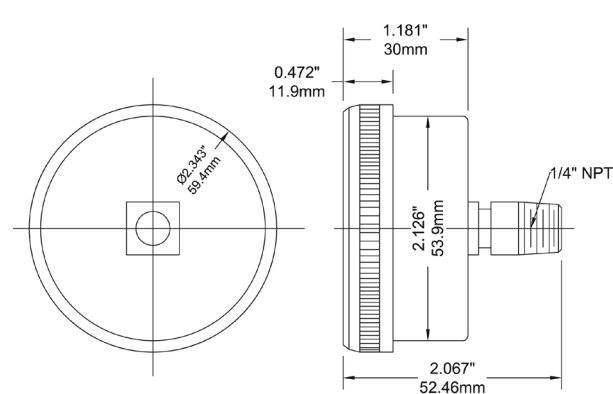

### 2.5" Bottom Connection

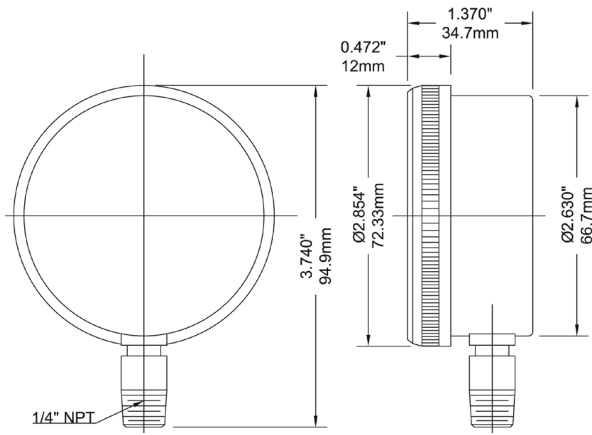

### 2.5" Back Connection

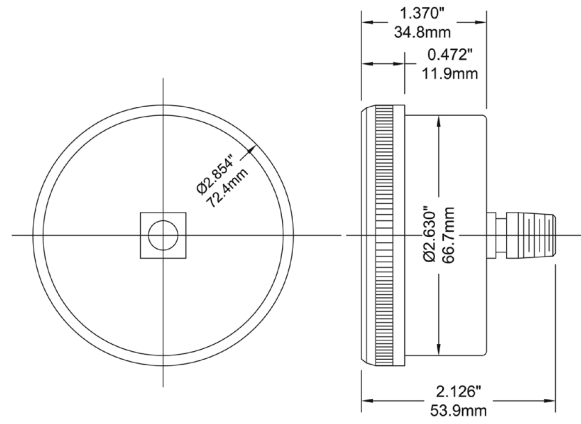

### 3.5" Bottom Connection

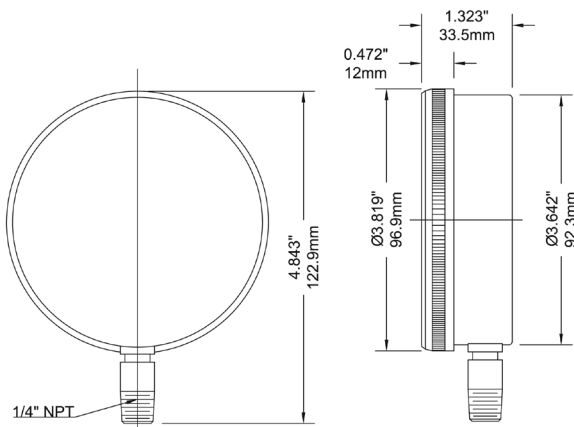

### 3.5" Back Connection

