

# HV590L Series Elevator Drive



**H**igh performance product

**N**ice customer experience

**C**losed-loop vector control



## Reliability

Adopted the best components, the prime optimized software algorithm, the most reliable structural design, strict inspection and test standards, long-time operation under severe field conditions

## Professionality

Developed by a group of technical specialists, based on mature frequency inverter technology, combined with multiple years of experiences in the elevator field



## Comfortability

By optimizing the Acc/Dec S-curves according to our performance testing feedbacks, HV590L offers you the best stable & comfortable passenger experience

## Usability

Unique groups of elevator parameters, perfect default values can meet most of the application requirements, which makes commissioning easy and straightforward, saves your time significantly

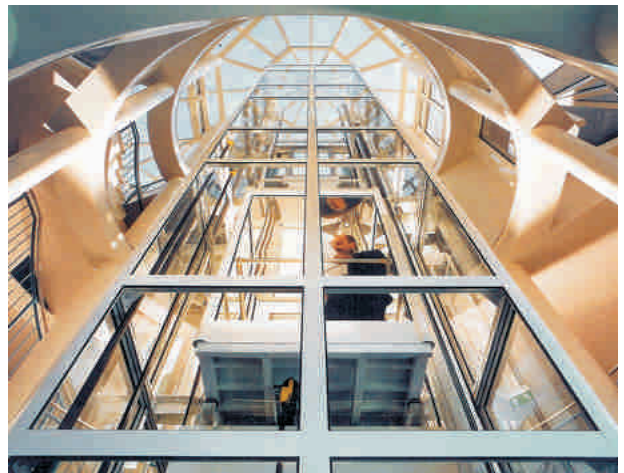



## Universality

HV590L supports multiple voltage grade, it adapt to different national grid specifications and requirements

## Accurately

Close-loop control mode could improve the control precision, HV590L provide a variety of encoder interface via PG card



## Durability

“IGBT Enable” function which worked together with the output contactor can eliminate arcing of contactor in an emergency , prolong the lifetime of output contactor

## Integrity

The MC and Brake control option is integrated in the default parameters of multi-functional output relay, makes the elevator running more reliable





## Model specification

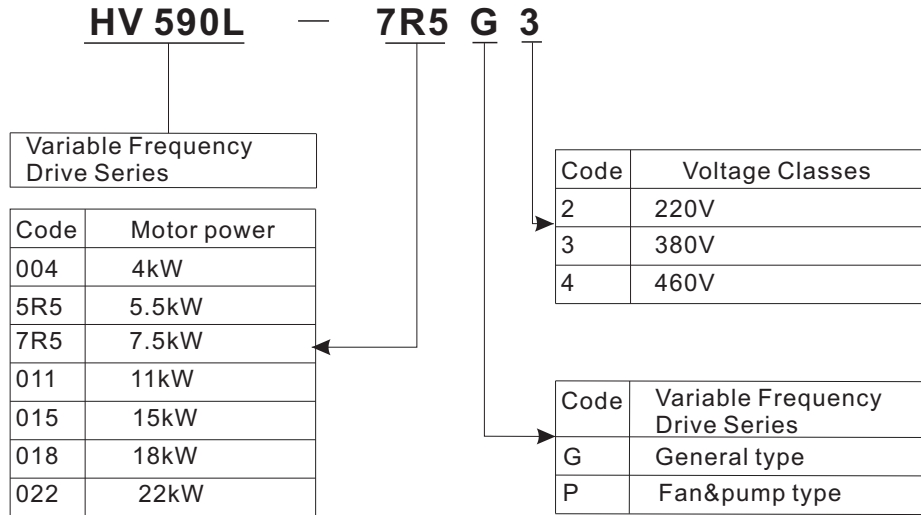

## Product model and braking resistor

Model	Braking unit	Braking resistor		Braking moment %
		Specifications	Quantity	
Three-phase input: AC 220V, 50/60Hz				
HV590L-004G2	Standard built-in	750W $\geq 45\Omega$	1	135
HV590L-5R5G2		1200W $\geq 22\Omega$	1	135
HV590L-7R5G2		1500W $\geq 16\Omega$	1	130
HV590L-011G2		2500W $\geq 13\Omega$	1	135
HV590L-015G2		3000W $\geq 10\Omega$	1	125
HV590L-018G2		4000W $\geq 8\Omega$	1	125
HV590L-022G2		4800W $\geq 6\Omega$	1	125
Three-phase input: AC 380V, 50/60Hz				
HV590L-004G3	Standard built-in	750W $\geq 130\Omega$	1	135
HV590L-5R5G3		1200W $\geq 90\Omega$	1	135
HV590L-7R5G3		1500W $\geq 65\Omega$	1	130
HV590L-011G3		2500W $\geq 43\Omega$	1	135
HV590L-015G3		3000W $\geq 32\Omega$	1	125
HV590L-018G3		4000W $\geq 28\Omega$	1	125
HV590L-022G3		4800W $\geq 25\Omega$	1	125
Three-phase input: AC 460V, 50/60Hz				
HV590L-004G4	Standard built-in	750W $\geq 150\Omega$	1	135
HV590L-5R5G4		1200W $\geq 110\Omega$	1	135
HV590L-7R5G4		1500W $\geq 78\Omega$	1	130
HV590L-011G4		2500W $\geq 52\Omega$	1	135
HV590L-015G4		3000W $\geq 38\Omega$	1	125
HV590L-018G4		4000W $\geq 34\Omega$	1	125
HV590L-022G4		4800W $\geq 30\Omega$	1	125



# HV590L

## Typical wiring diagram

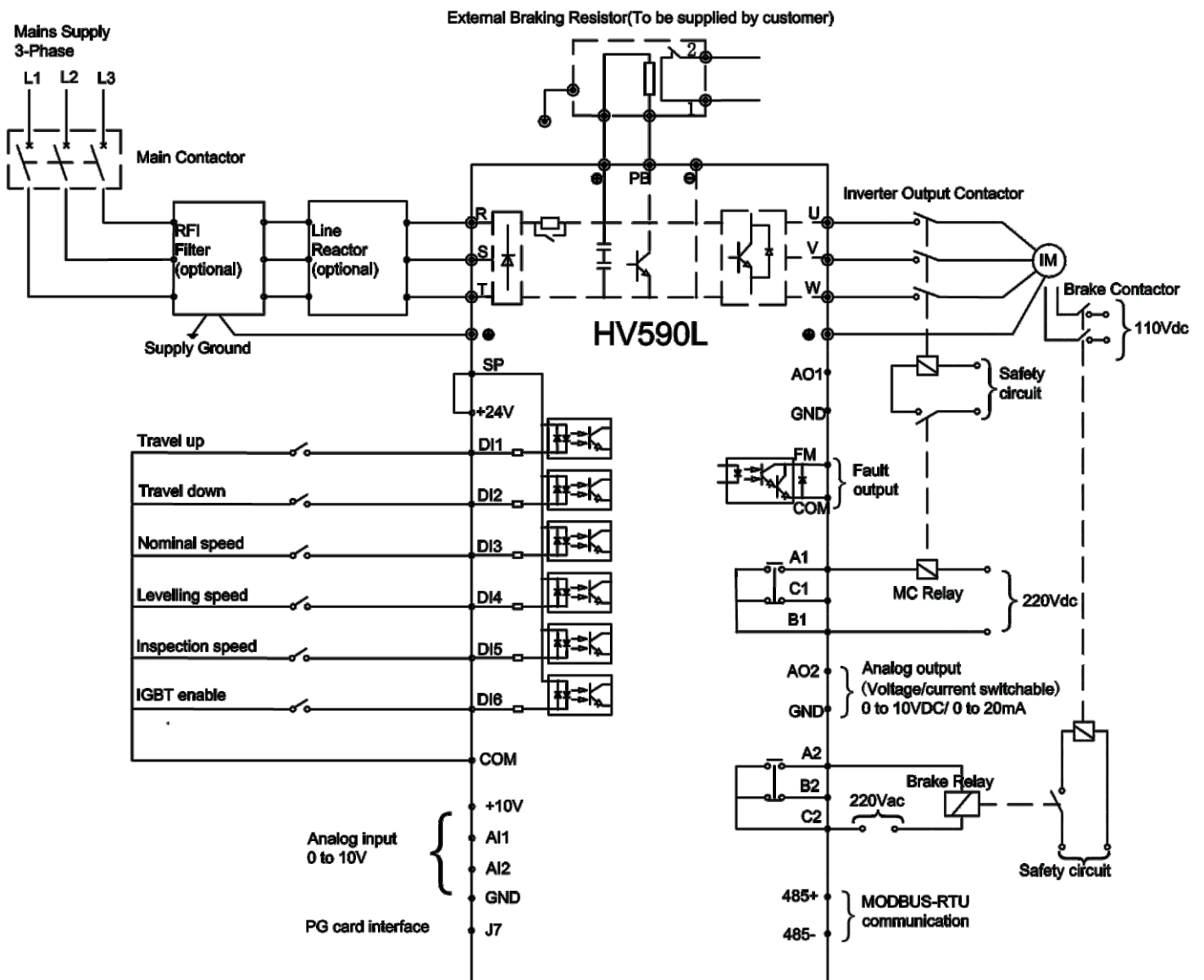



## Quicksetup

Complete timing diagram for normal travel ( Use multi- reference as frequency reference)

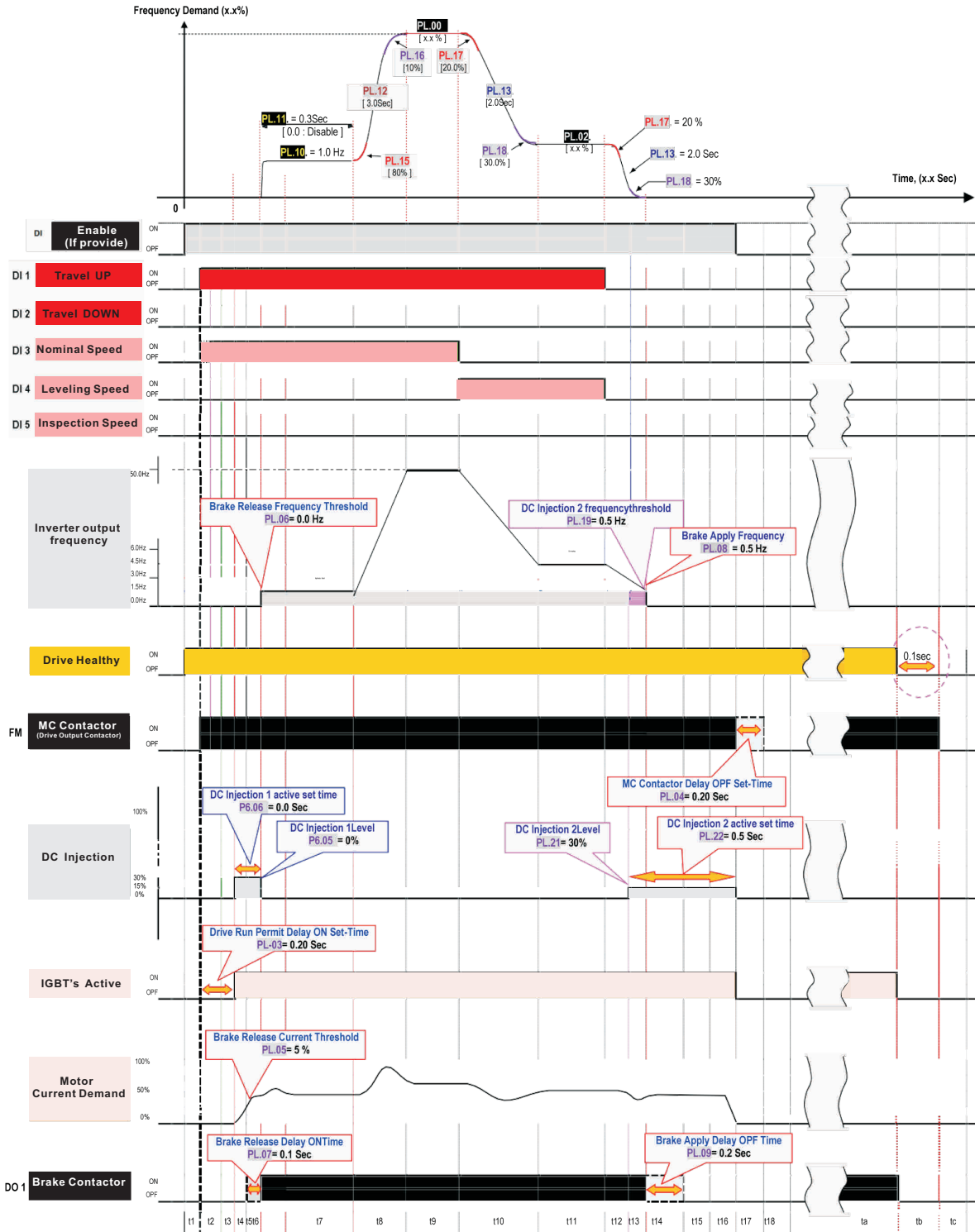



Event	Descriptions	Function	Drive Status
t <sub>a</sub>	<ul style="list-style-type: none"> <li>– Drive healthy</li> <li>– MC and brake Contactor are energized</li> </ul>	----	RUN
t <sub>b</sub>	<ul style="list-style-type: none"> <li>– Drive Trip</li> <li>– IGBTs disable</li> <li>– Brake contactor de-energized</li> </ul>	----	Trip
t <sub>c</sub>	<ul style="list-style-type: none"> <li>– MC contactor got de-energized provided drive IGBTs are disabled after 0.1sec</li> </ul>	----	Trip
t <sub>1</sub>	<ul style="list-style-type: none"> <li>– Drive waits to enable by lift controller</li> </ul>	----	Inhibit
t <sub>2</sub>	<ul style="list-style-type: none"> <li>– Drive MC contactor output energized when direction demand command enable by the lift controller.</li> <li>– Desired preset speed reference command enable by lift controller</li> </ul>	PL.03	Ready
t <sub>3</sub>	<ul style="list-style-type: none"> <li>– Drive IGBTs immediately go into active mode after the desire drive run permit delay ON set time has elapse</li> </ul>	PL.03	STOP
t <sub>4</sub>	<ul style="list-style-type: none"> <li>– DC injection active</li> <li>– Motor brake contactor energized when motor current demand excess the brake release current level and brake release frequency</li> </ul>	PL.05 PL.06 PL.05 PL.06	RUN
t <sub>5</sub>	<ul style="list-style-type: none"> <li>– Motor brake contactor is energized</li> <li>– Optimize profile generator active</li> <li>– Motor start to run</li> </ul>	PL.07 PL.10 PL.11	RUN
t <sub>6</sub>	<ul style="list-style-type: none"> <li>– DC injection 1 disable after the desired set time has elapsed</li> </ul>	PL.06	RUN
t <sub>7</sub>	<ul style="list-style-type: none"> <li>– Start optimizer profile generator disable after the desired set time has elapse</li> </ul>	PL.11	RUN
t <sub>8</sub>	<ul style="list-style-type: none"> <li>– Motor ramp up to the desire preset speed reference</li> </ul>	PL.15 PL.16 PL.12 PL.0x	RUN
t <sub>9</sub>	<ul style="list-style-type: none"> <li>– Drive output at speed status</li> </ul>	PL.01	RUN
t <sub>10</sub>	<ul style="list-style-type: none"> <li>– Change of preset speed reference demand</li> <li>– Motor ramp down to the desire preset speed reference</li> </ul>	PL.15 PL.16 PL.12 PL.0x	RUN
t <sub>11</sub>	<ul style="list-style-type: none"> <li>– Drive output at speed status</li> </ul>	PL.0x	RUN
t <sub>12</sub>	<ul style="list-style-type: none"> <li>– Direction demand command disabled</li> <li>– Motor ramp down to zero speed</li> </ul>	PL.17 PL.18 PL.13	RUN
t <sub>13</sub>	<ul style="list-style-type: none"> <li>– DC injection active when drive output falls below the –DC injection 2 frequency threshold</li> </ul>	PL.19 PL.21	RUN
t <sub>14</sub>	<ul style="list-style-type: none"> <li>– Brake contactor got de-energize when the drive output frequency fall below the brake apply frequency</li> </ul>	PL.06 PL.09	RUN
t <sub>15</sub>	<ul style="list-style-type: none"> <li>– DC injection still active when brake contactor got de-energize</li> </ul>	PL.21	RUN
t <sub>16</sub>	<ul style="list-style-type: none"> <li>– DC injection disable after the desire set time has elapse</li> </ul>	PL.22	STOP
t <sub>17</sub>	<ul style="list-style-type: none"> <li>– Drive IGBTs got disable</li> <li>– MC contactor delay OFF time active</li> </ul>	----	Ready
t <sub>18</sub>	<ul style="list-style-type: none"> <li>– MC contactor de-energize after the desire se</li> </ul>	PL.04	Inhibit



## Parameter Group L-Elevator Parameters

Para	Parameter Name	Default Value	Commissioning
Set multi-reference value			
PL.00	Normal speed	100	100
PL.01	Leveling speed	11	11
PL.02	Maintenance speed	40	40
Set magnetic contactor			
PL.03	Drive run delay On set time	0.2	0.2
PL.04	Main contactor (MC) delay Off set time	0.2	0.2
Set brake contactor		5	5
PL.05	Brake release current threshold	0	0
PL.06	Brake release frequency threshold	0	0
PL.07	Brake release delay On set time	0.5	0.5
PL.08	Brake apply frequency threshold	0.2	0.2
PL.09	Brake apply delay OFF set time	28.0	25
Set Startup frequency			
PL.10	Startup frequency	1	1
PL.11	Startup frequency active set time	0.3	0.3
Set acceleration and deceleration			
PL.12	Acceleration time 1	3	3
PL.13	Deceleration time 1	2	2
Set S-curve			
PL.14	Acceleration/deceleration mode	3	3
PL.15	Time proportion of S-Ramp at acc Start	80	80
PL.16	Time proportion of S-Ramp at acc end	10	10
PL.17	Time proportion of S-Ramp at dec Start	20	20
PL.18	Time proportion of S-Ramp at dec end	30	30
Set DC injection for stopping			
PL.19	DC injection 2 frequency threshold	0.5	0.5
PL.20	DC injection 2 delay on set time	0	0
PL.21	DC injection 2 level	30	30
PL.22	DC injection 2 active set time	0.5	0.5
Set Emergency action			
PL.23	Emergency action enable	0	0
PL.24	Emergency action voltage threshold	350	350

Note: The detailed explanation, please reference "HV590L User manual".





## Standard specification

Items		Description		
Basic function	Input voltage classes	3-phase input: AC 220V, 50/60Hz; AC 380V, 50/60Hz; AC 460V, 50/60Hz		
	Control system	High performance of current vector control technology to realize asynchronous motor and synchronous motor control		
	Maximum frequency	Vector control: 0~300HzV/Fcontrol: 0~3200Hz		
	Carrier frequency	0.5k~16kHz; The carrier frequency will be automatically adjusted according to the load characteristics		
	Input frequency resolution	Digital setting: 0.01Hz Analog setting: maximum frequency ×0.025%		
	Control mode	Open loop vector control(SVC) Closed loop vector control(FVC) V/F control		
	Startup torque	Type G: 0.5Hz/150%(SVC); 0Hz/180%(FVC)		
	Speed range	1: 100(SVC)	Speed range	
	Speed stabilizing precision	±0.5%(SVC)	Speed stabilizing precision	
	Torque control precision	±5%(FVC)		
	Over load capability	G type: rated current 150% -1 minute, rated current 180% -3 seconds;		
	Torque boost	Auto torque boost function; Manual torque boost 0.1%~30.0%		
	V/F curve	Linear V/F,Multi-point V/F and Square V/F curve (power of 1.2, 1.4, 1.6, 1.8, 2)		
	Acc /dec curve	Straight line or S curve acceleration and deceleration mode. Four kinds of acceleration and deceleration time. Acceleration and deceleration time range between 0.0s to 6500.0s		
	DC brake	DC brake frequency: 0.00Hz to maximum frequency, brake time: 0.0s to 36.0s, and brake current value: 0.0% to 100.0%.		
	Jog control	Jog frequency range: 0.00Hz~50.00Hz. Jog acceleration/deceleration time 0.0s~6500.0s.		
MS speed running	It can realize at maximum of 16 segments speed running via the built-in PLC or control terminal.			



Items		Description
	Auto voltage regulation (AVR)	It can keep constant output voltage automatically in case of change of network voltage.
	Over-voltage/current stall control	It can limit the running voltage/current automatically and prevent frequent over-voltage/current tripping during the running process
	Quick current limit	Minimize the over-current fault, protect normal operation of the inverter
	Torque limit & control	"Excavators" characteristics, automatically limit torque during operation, prevent frequent over-current trip; Closed loop vector mode can realize the torque control
Personalized	Instantaneous stop non-stop	When instantaneous power off, voltage reduction is compensated through load feedback energy, which could make inverter keep running in a short period of time.
	Rapid current limit	To avoid inverter frequent over-current fault.
	Encoder support	Support difference, open collector, UVW, rotary transformer, sine cosine encoder etc.
Running	Running command channel	Three types of channels: operation panel reference, control terminal reference and serial communication port reference. These channels can be switched in various modes.
	Frequency source	There are totally eleven types of frequency sources, such as digital reference, analog voltage reference, analog current reference, pulse reference, MS speed, PLC, PID and serial port reference.
	Input terminal	11 kinds of auxiliary frequency source which can flexibly achieve auxiliary frequency tuning, frequency synthesis
	Output terminal	Standard: 1 digital output terminals, Y1 is high-speed pulse output terminal (can be chosen as open circuit collector type), support 0~10kHz square wave signal; 2 relay output terminal; 2 analog output terminals, support 0~20mA output current or 0~10V output voltage; Extended card HV590IO2: 1 channel collector output: DO2 2 channel relay: TA3, TB3, TC3 1 analog output terminal, support 0~20mA output current or 0~10V output voltage.
	Protection function	It can implement power-on motor short-circuit detection, input/output phase loss protection, over current protection, over voltage protection, under voltage protection, overheating protection and overload protection.
	Optional parts	1, Brake component 2, Multi-function I/O card HV590IO1, HV590IO2 3, Differential & Open-collector input PG card HV590PG1: Optional 5V/12V/24V. without dividing frequency output



# HV590L

Items		Description
Environment	Using place	Indoor, and be free from direct sunlight, dust, corrosive gas, combustible gas, oil smoke, vapor, drip or salt.
	Altitude	Below 1000m
	Ambient temperature	-10 °C to +40 °C (Derating use when under ambient temperature of 40 °C to 50 °C)
	Humidity	Less than 95%RH, without condensing
	Vibration	Less than 5.9 m/s (0.6g)
	Storage temperature	-20°C~+60°C

Note: About optional parts, the 4KW type don't support any of them; the 5.5 and 7.5KW type can support all, but only one of them can be installed each time; the 11kw and above type can support all, but only two of them can be installed each time.



## Product Component Name

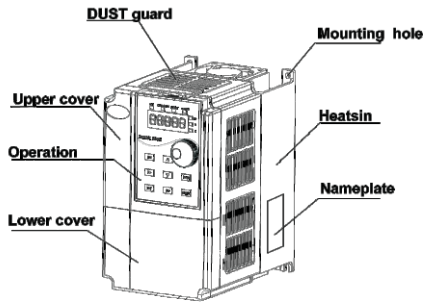

HV590L-7R5G3 and below power class

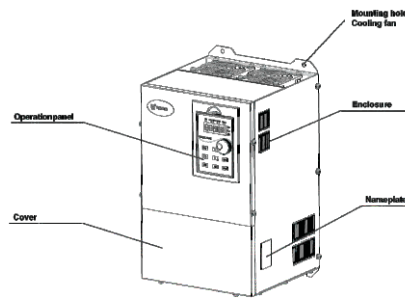

HV590L-011G3 and above power class

## Product Outline, Mounting Dimension, and Weight

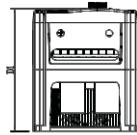
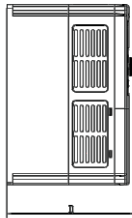
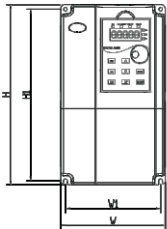

HV590L-7R5G3 and below power class

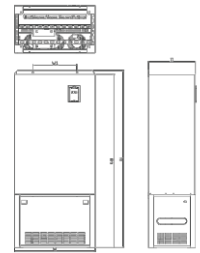
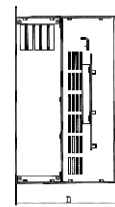
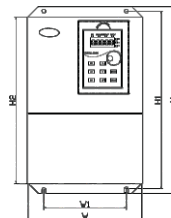

HV590L-011G3 and above power class

Shape DIM	Shape Dimension And Installation Dimension(mm)								Weight (kg)
	W	H	D	W1	H1	D1	H2	Assembly aperture	
Three-phase input: AC 220V, 50/60Hz									
HV590L-004G2	150	258	183.8	136.8	245	175.3		5.5	4.0
HV590L-5R5G2	210	337	191	150	322.5		298	7	8.7
HV590L-7R5G2	210	337	191	150	322.5		298	7	8.7
HV590L-011G2	221	380	229.6	163	363.6		341	7	10
HV590L-015G2	221	380	229.6	163	363.6		341	7	10
HV590L-018G2	285	501	230.2	200	482		460	7	19
HV590L-022G2	352	585	274.2	220	559		538	10	35
Three-phase input: AC 380V, 50/60Hz									
HV590L-004G3	118.5	195	169	106.5	184.5	160		5.5	2.6
HV590L-5R5G3	150	258	183.8	136.8	245	175.3		5.5	4.0
HV590L-7R5G3									
HV590L-011G3	210	337	191	150	322.5		298	7	8.7
HV590L-015G3	221	380	229.6	163	363.6		341	7	10
Three-phase input: AC 460V, 50/60Hz									
HV590L-004G4	118.5	195	169	106.5	184.5	160		5.5	2.6
HV590L-5R5G4	150	258	183.8	136.8	245	175.3		5.5	4.0
HV590L-7R5G4									
HV590L-011G4	210	337	191	150	322.5		298	7	8.7
HV590L-015G4	221	380	229.6	163	363.6		341	7	10



## Trouble shooting

Timing Table

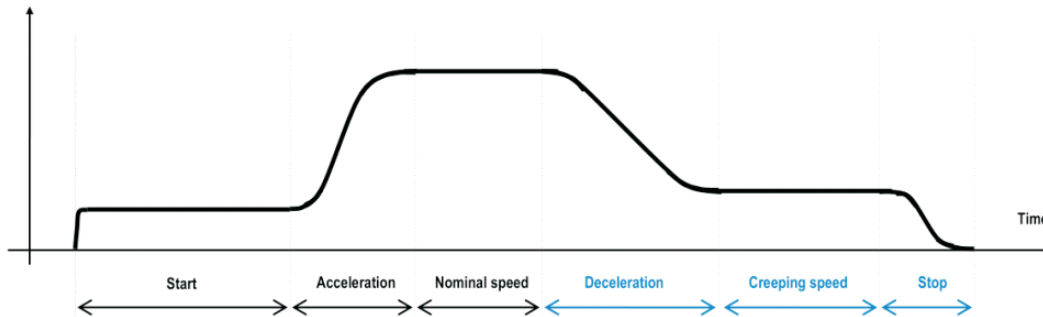

Stage	Symptom	Diagnostics	Remedies
Start	Rollback	Brake device releases too early	Increase PL.07, ranging 0 to 0.5s Applicable only if Drive Controls M/C Brake
		Start frequency is too low	Increase PL.10, ranging 0 to 1.5Hz
	Jerk	Torque output is insufficient	Ensure P3.00=0, P3.01=0
		Brake device releases too late	Decrease PL.07, ranging 0 to 0.5s Applicable only if Drive Controls M/C Brake
Acceleration	Jerk when acceleration starts	Accel rate too fast	Increase PL.15, ranging 0 to 80% Or increase PL.12, ranging 0 to 20s
	Jerk when acceleration ends	Accel rate too fast	Increase PL.16, ranging 0 to (95-(PL.15))% Or increase PL.12, ranging 0 to 20s
	Overshoot when acceleration ends	Speed loop PI over gain	Decrease P2.03, ranging 0 to 100 Or increase P2.04, ranging 0 to 10
	Vibration	Too small margin between P2.02 and P2.05	Make sure P2.05-P2.02>3Hz, usually increase P2.05, ranging from P2.02 to 7Hz
Overcurrent stall prevention occurs		Ensure P3.18=170%	
Nominal	Vibration	Speed loop PI over gain	Decrease P2.00 or P2.03, ranging 0 to 100, or increase P2.04 or P2.04, ranging 0.01 to 10.00
		Current loop PI over gain	Double check the motor parameters and then perform motor auto-tuning once more
Deceleration	Jerk when acceleration starts	Deceleration rate too fast	Increase PL.18, ranging 0 to 80%, Or increase PL.13, ranging 0 to 20s
	Vibration	Overcurrent stall prevention occurs	Make sure P3.18=170%
	Jerk when acceleration ends	Deceleration rate too fast	Increase PL.18, ranging 0 to 80%, Or increase PL.13, ranging 0 to 20s



Stage	Symptom	Diagnostics	Remedies
Creeping	Vibration	Insufficient torque output	Ensure P3.00=0, P3.01=0
	Elevator at half	Insufficient torque output	Ensure P3.00=0, P3.01=0
	Move much slower than expected	Insufficient torque output	Ensure P3.00=0, P3.01=0
Adjust creeping speed		Increase P4.16, ranging 0 to 100% or decrease relevant multi-reference	
Stopping	Jerk	Deceleration rate too fast	Increase PL.18, ranging 0 to 80%
			Increase PL.13, ranging 0 to 20s
		Use second deceleration time P8.04: First, set P8.04 bigger than PL.13, ranging PL.13 to 20s; then set P8.26=creeping speed	
		Braking device applies too early	Make sure PL.08=0.5Hz, then increase PL.09, ranging 0 to 0.5s
	DC injection overgain	Decrease PL.21, ranging 0 to 100%	
	Slip	DC injection gain time too short	Increase PL.22, ranging 0 to 1s
		DC injection gain step point too low	Increase PL.21, ranging 0 to 100%
		Brake apply delay too long	Ensure PL.08=0.5Hz, then decrease PL.09, ranging 0 to 0.5s
	Inaccurate leveling position	Too slow deceleration	If P8.04 is not applied, then decrease PL.13, ranging 0 to 20s
If P8.04 is applied, then firstly decrease/increase P8.04; secondly set P8.26=creeping speed			
If P0.01=2, increase P3.09=Slip compensation gain(0~200%)			
If P0.01=0, increase/decrease P2.06=Vector slip gain(50~200%)			



# HV590L

## About HNC Electric

HNC Electric is an automation & drive focused global company, providing global customers with control, display, drive and system solutions & other related products and services, under the support of its excellent electrical and electronic technology as well as strong control technical force.

HNC Electric listen and understand our clients requirement, by improving and upgrading our product functions and performance continuously , we provide and develop perfect products and solutions according to different requirement of the industry. Our products have been used and applied successfully in packing, printing, textiles, plastic injection, elevator, machine tool, robot, wood cutting, stone carving, ceramic, glass, paper making industry, crane, fan & pump, new energy resources etc.

In order to provide more complete service and product for our customers internationally, meeting our customer expectations in the respect of time of delivery, solution support, after sales services and product customization support, HNC Electric has been searching for capable companies as our business partners, product agents and distributors, bringing good product quality and professional service to our clients globally. Up until now, we have already got customers and business partnerships built up in over 40 countries, which include Europe, North America, South America, Asian-pacific region, Middle East and Australia etc.

The superior quality and low cost of HNC Electric's product are benefited from the mature and complete manufacturing system and the efficient logistic of China. Our talented and sufficient manpower, our rich engineering experiences, drives our product to be more complete and better in the respect of functions and performances.

HNC Electric, your professional electrical partner !





**HNC Electric Limited**

Tel: +86 020 84898493

Email: [info@hncelectric.com](mailto:info@hncelectric.com)

Address: UNIT 04,7/F., BRIGHT WAY TOWER, NO. 33 MONG KOK ROAD.KL,Hongkong

Website: [www.hncelectric.com](http://www.hncelectric.com)

